



INSTALLATION MANUAL

VELCRO AND ROLL TONNO COVER



WARNING

Tighten clamps securely on side rails before driving vehicle, to prevent cover from blowing off.

Parts included in the Assembly:

Item	Description	Qty
RA	Tonno Tarp, with Front Bar and Rear Bar and Crossbow	1
RB	Left side rail	1
RC	Right side rail	1
RG	Clamp assembly	6
RH	Adjustable Setting Knob	2

REQUIRED TOOLS: 1 Allen Wrench 3/16", Measure Tape

STEPS:

1. Check Contents of carton with the list above
2. Place the Right side rail (Item RC) and Left side rail (Item RB) on each side of truck bed.
3. Insert the clamps (Item RG) inside the side rail inner groves. Distribute evenly the clamps on each side of the cover (see picture). Tighten loosely the clamps with the Allen wrench

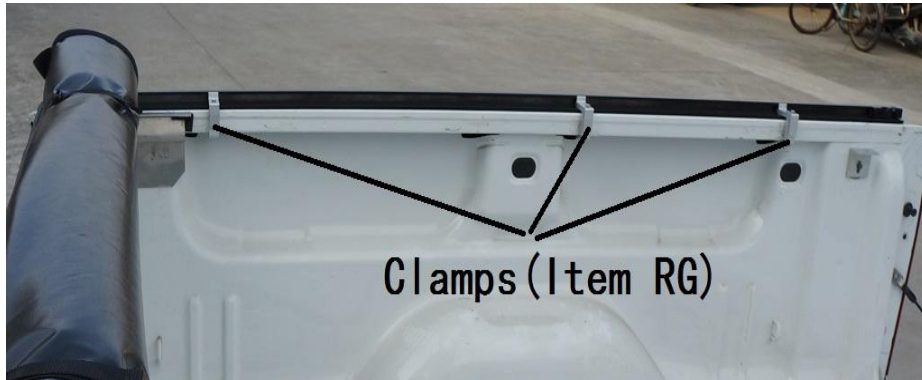

4. Insert Front Bar (item RA) into the 2 Side rails (item RB and RC), and tighten the Knobs (RH). (Pay attention to the position of the Knobs in the picture bellow)

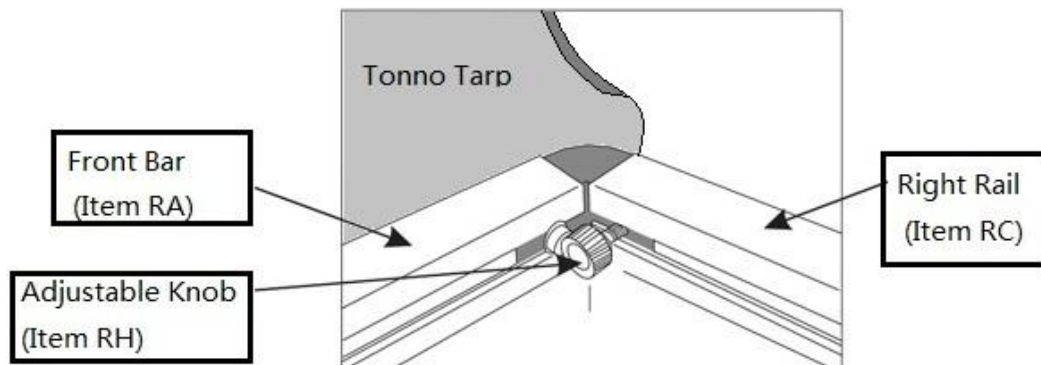

5. Attach front bar & cover assembly by inserting corners (Step4), Align frame from front to rear and side to side.



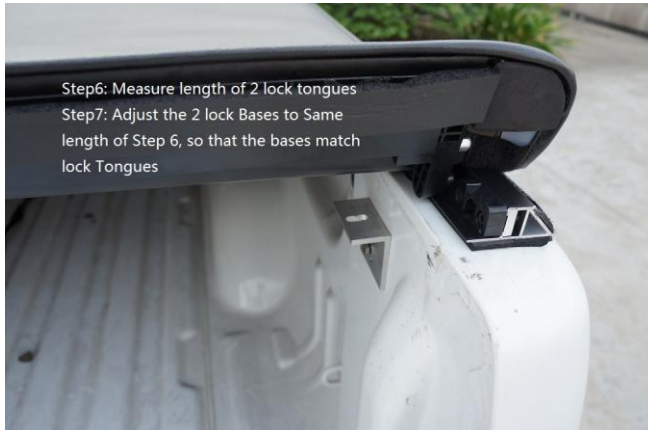

6. Measure the length between the outside of 2 metal Locking Tongues (The metal locking tongue is on each side of Rear Bar), record the length.
7. Adjust the distance between 2 Side Rails on the truck bed, make sure the distance between the 2 Locking Bases is adjusted to same length as the result of Step 6. (The Locking Base is on the rear end of Side Rail)
8. Then tighten the Clamps tightly on the side rails with the Allen wrench.
9. Pull the Tonno Tarp, push down the Rear Bar, close and lock the Rear Bar



10. To open the cover, open the truck bed tailgate, pull the handle in the middle of the cover Rear Bar, unlock the bar, roll up the whole cover to the front of truck bed, then use the buckles to secure the rolled tarp.



Attention: For Nissan/Toyota trucks (with Utility Tracks) only

The Item RG (Clamp assembly) will become a bracket set as bellow photo (Item 8-A,B,C). Follow bellow steps to assemble the side rails(RB,RC) on the truck bed:

Place the frame(RB,RC) on the bed, and insert the clamps (item 8-A) inside the side rail(RB,RC) inner grooves.

Distribute evenly the clamps on each side of the cover. Tighten the hex nut (item 8-B) on clamps.

Slide the aluminum block (item 8-C) in the truck bed factory track(see picture bellow), and tighten the aluminum block and clamps with the Allen wrench. (see picture bellow)

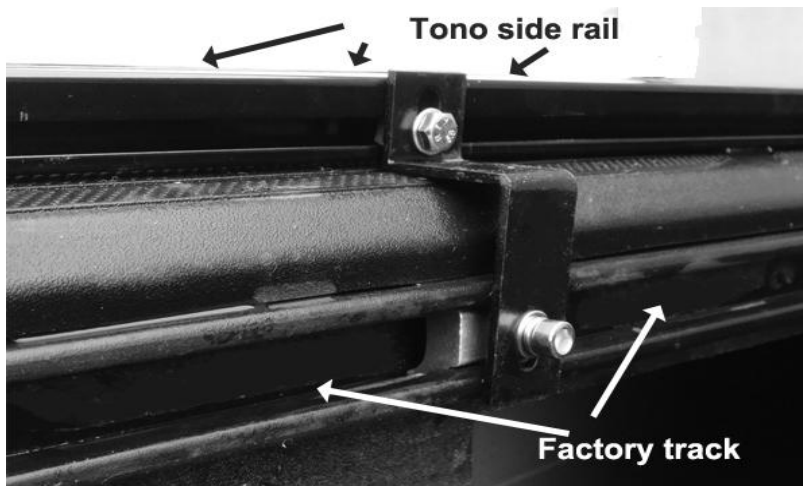
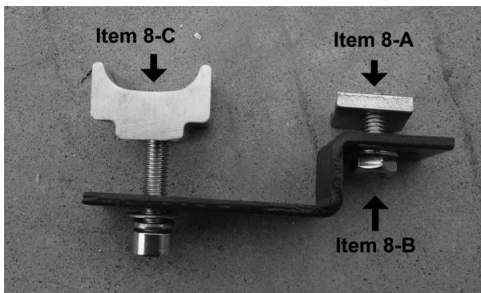

NOTE: Tension is pre-set, however it may be necessary to adjust the tension of the vinyl. Looser if the cover is difficult to secure, or tighter if the cover is easily to secure.

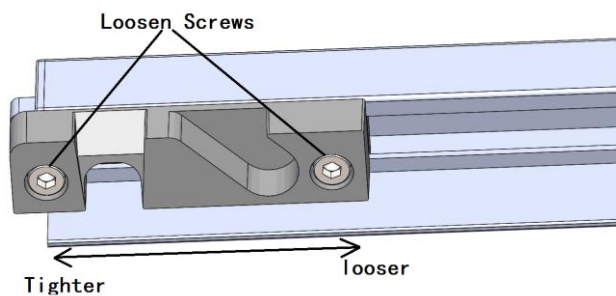

WARNING-CARE OF THE COVER TARP

Do not use cleaners for plastic or detergents. Clean the tarp with neutral soap and water